

MW-II

Micro Weighing Scale

- Full Featured
- High Accuracy
- Weighing Modes (g, kg, ct, lb, oz, mom, gn, tl, dwt)
- Counting Function
- Optional Rechargeable Battery

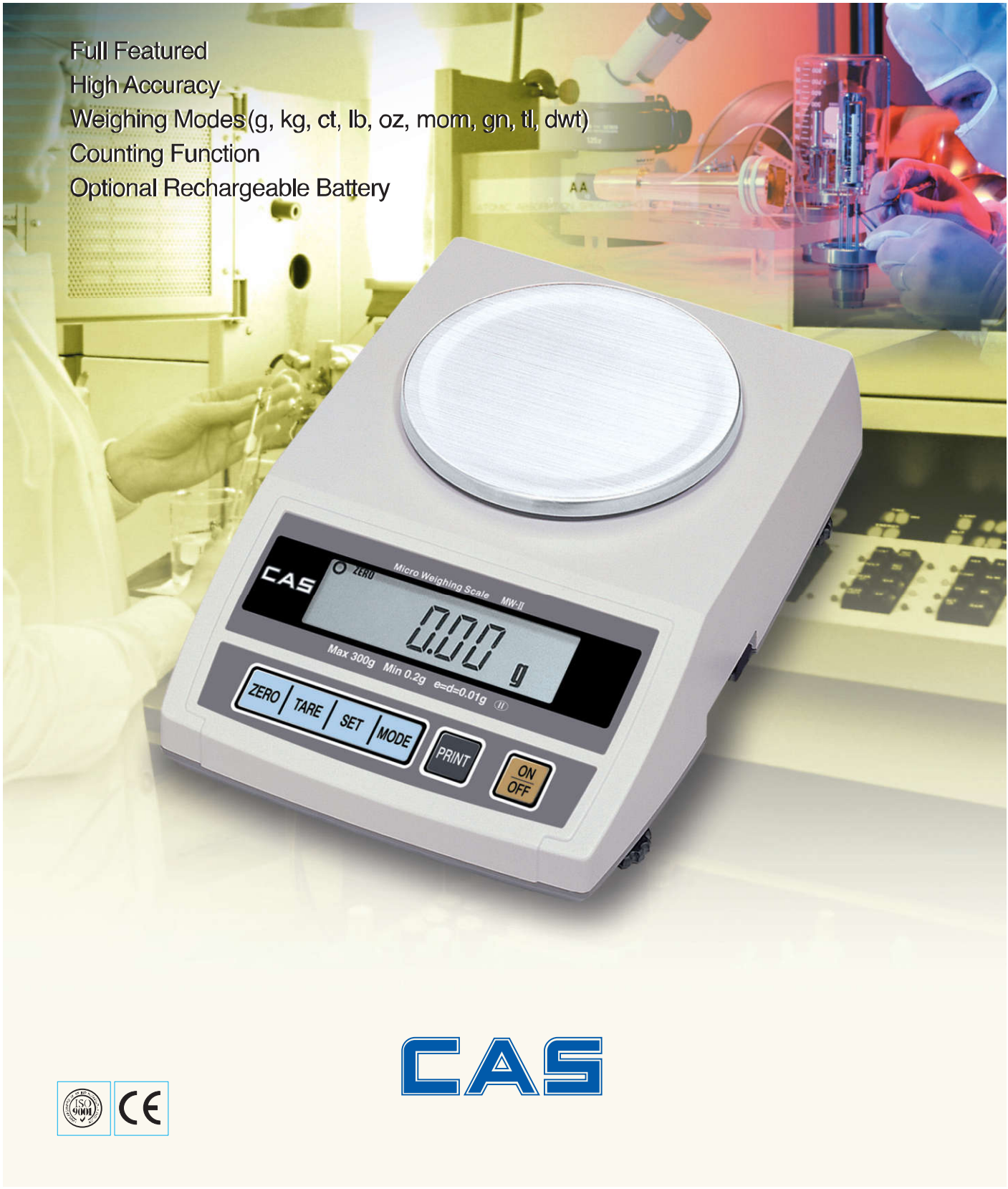

CAS

MW-II Micro Weighing Scale

FEATURES

- High accuracy
(External resolution : 1/20,000 ~ 1/30,000)
- Convertible Unit Weight
(g, ct, lb, oz, dwt, mom, GN, tl)
- Counting function
- Percent weighing mode
- Auto power off, Back-light auto On/Off
- Battery check function
- Printing weight, date and time
- RS232C interface (PC, Printer)

SPECIFICATIONS

Model	MW-II			
Weighing Capacity	200/0.01g	300/0.01g	2kg/0.1g	3kg/0.1g
Maximum Tare	200g	300g	2kg	3kg
Display	LCD (6 Digits)			
Power Source	DC 12V 300mA AC Adaptor AC 110/220V, 50/60Hz			
Power Consumption	0.4W			
Operating Temperature	-10°C ~ +40°C			
Platter Size (mm)	Ø130	158(W) x 144.6(D)		
Dimensions (mm)	190(W) x 271(D) x 83.5(H)			
Product Weight	1.03kg	3kg		

OPTIONS

- Back-light Display
The battery life is cut down 30~40% by using Back-Light.
- Rechargeable Battery
NiCd/NiMH Battery (7.2V)
Adaptor DC 12V/850mA
20 hours (NiMH battery)
- Rear Display
- Printer
DEP-50 (Receipt printer)



DIMENSIONS

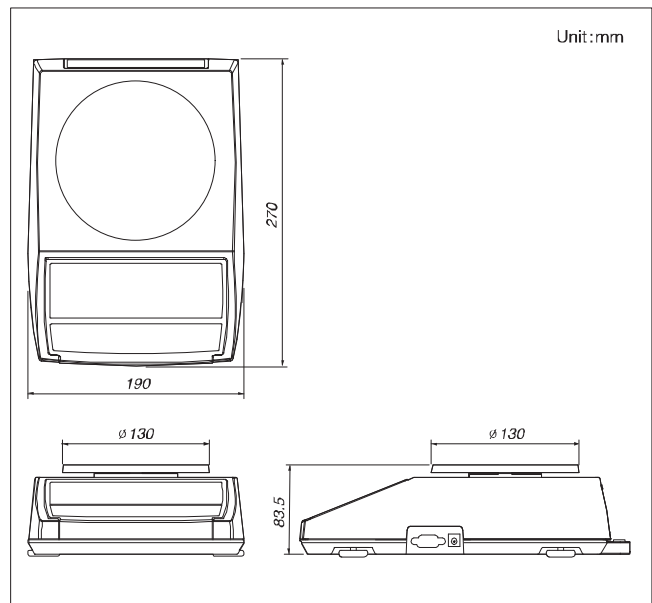

CAS

CAS BLDG., # 440-1, SUNGNAE-DONG,
GANGDONG-GU, SEOUL, KOREA
TEL : 82-2-2225-3500
FAX : 82-2-475-4668
<http://www.cas.co.kr>

Specifications are subject to change for improvement without prior notice.